

# R&S® ZVA-Zxx Millimeter-Wave Converters Specifications



## CONTENTS

<b>Definitions</b> .....	<b>3</b>
<b>General information</b> .....	<b>4</b>
<b>Specifications</b> .....	<b>5</b>
Test port.....	5
Source input (RF IN) .....	6
Local oscillator input (LO IN) .....	6
Measurement output (MEAS OUT) .....	7
Reference output (REF OUT) .....	7
Attenuation control input (ATT), R&S®ZVA-Z110E only .....	7
System characteristics.....	8
Power supply input.....	15
General data .....	15
<b>Ordering information</b> .....	<b>19</b>

# Definitions

## General

Product data applies under the following conditions:

- Three hours storage at ambient temperature followed by 30 minutes warm-up operation
- Specified environmental conditions met
- Recommended calibration interval adhered to
- All internal automatic adjustments performed, if applicable

## Specifications with limits

Represent warranted product performance by means of a range of values for the specified parameter. These specifications are marked with limiting symbols such as  $<$ ,  $\leq$ ,  $>$ ,  $\geq$ ,  $\pm$ , or descriptions such as maximum, limit of, minimum. Compliance is ensured by testing or is derived from the design. Test limits are narrowed by guard bands to take into account measurement uncertainties, drift and aging, if applicable.

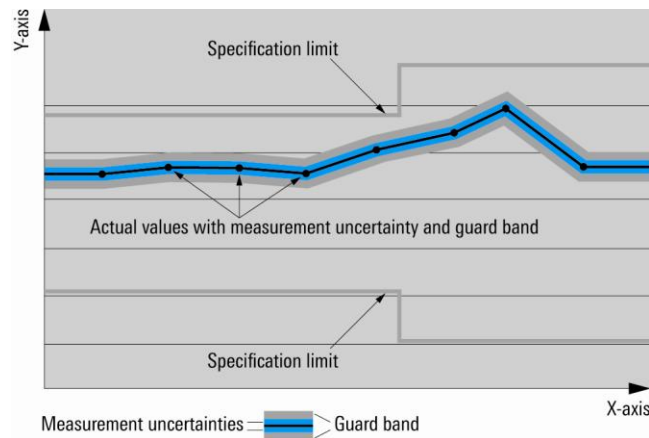

## Non-traceable specifications with limits (n. trc.)

Represent product performance that is specified and tested as described under “Specifications with limits” above. However, product performance in this case cannot be warranted due to the lack of measuring equipment traceable to national metrology standards. In this case, measurements are referenced to standards used in the Rohde & Schwarz laboratories.

## Specifications without limits

Represent warranted product performance for the specified parameter. These specifications are not specially marked and represent values with no or negligible deviations from the given value (e.g. dimensions or resolution of a setting parameter). Compliance is ensured by design.

## Typical data (typ.)

Characterizes product performance by means of representative information for the given parameter. When marked with  $<$ ,  $>$  or as a range, it represents the performance met by approximately 80 % of the instruments at production time. Otherwise, it represents the mean value.

## Nominal values (nom.)

Characterize product performance by means of a representative value for the given parameter (e.g. nominal impedance). In contrast to typical data, a statistical evaluation does not take place and the parameter is not tested during production.

## Measured values (meas.)

Characterize expected product performance by means of measurement results gained from individual samples.

## Uncertainties

Represent limits of measurement uncertainty for a given measurand. Uncertainty is defined with a coverage factor of 2 and has been calculated in line with the rules of the Guide to the Expression of Uncertainty in Measurement (GUM), taking into account environmental conditions, aging, wear and tear.

Device settings and GUI parameters are indicated as follows: “parameter: value”.

Non-traceable specifications with limits, typical data as well as nominal and measured values are not warranted by Rohde & Schwarz.

## General information

The R&S®ZVA-Zxx millimeter-wave converters are optional external supplements for the four-port vector network analyzers (R&S®ZVT20, with at least four ports, R&S®ZVA24, R&S®ZVA40, R&S®ZVA50 or R&S®ZVA67), allowing measurements in the frequency range from 75 GHz to 500 GHz. Converters are available for the frequency bands from 50 GHz to 75 GHz (R&S®ZVA-Z75), 60 GHz to 90 GHz (R&S®ZVA-Z90), 75 GHz to 110 GHz (R&S®ZVA-Z110 and R&S®ZVA-Z110E), 90 GHz to 140 GHz (R&S®ZVA-Z140), 140 GHz to 220 GHz (R&S®ZVA-Z220), 220 GHz to 325 GHz (R&S®ZVA-Z325) and 325 GHz to 500 GHz (R&S®ZVA-Z500).

They consist of a reflectometer module containing a directional coupler, a frequency multiplier for the generation of the source signal, two harmonic mixers as downconverters, and a manually or electronically adjustable attenuator that allows the output power to be varied. In addition, the R&S®ZVA-Z90, as well as the R&S®ZVA-Z110, allow output power setting by adjusting the RF input power.

The four-port network analyzer must be equipped with the R&S®ZVxx-B16 and R&S®ZVA-K8 options.  
For the R&S®ZVA-Z110E, the R&S®ZVA-B8 option is additionally recommended.

The R&S®ZVA-Zxx converters come with the following:

- DC power adapter for the input voltage range from 100 V to 240 V (AC) with  $\pm 10\%$  tolerance
- Hex ball driver
- Two coaxial cables with SMA connectors for the reference and measurement output signals
- Waveguide-to-waveguide adapter acting as test port saver

# Specifications

## Test port

Frequency range	R&S® ZVA-Z75	50 GHz to 75 GHz
	R&S® ZVA-Z90	60 GHz to 90 GHz
	R&S® ZVA-Z110 and R&S® ZVA-Z110E	75 GHz to 110 GHz
	R&S® ZVA-Z220	140 GHz to 220 GHz
	R&S® ZVA-Z325	220 GHz to 325 GHz
Waveguide designator Electronic Industries Alliance (EIA)	R&S® ZVA-Z75	WR15
	R&S® ZVA-Z90	WR12
	R&S® ZVA-Z110 and R&S® ZVA-Z110E	WR10
	R&S® ZVA-Z220	WR05/WR5.1
	R&S® ZVA-Z325	WR03/WR3.4
Connector type	anti-cocking flange	precision waveguide flange compatible with UG387/U-M
Output power	at +7 dBm input power from the R&S® ZVA	
	R&S® ZVA-Z75	> 0 dBm, 4 dBm (typ.)
	R&S® ZVA-Z90	> 6 dBm, 10 dBm (typ.)
	R&S® ZVA-Z110	> 7 dBm, 10 dBm (typ.)
	R&S® ZVA-Z110E	
	75 GHz to 95 GHz	> -6 dBm, -3 dBm (typ.)
	95 GHz to 105 GHz	> -8 dBm, -5 dBm (typ.)
	105 GHz to 110 GHz	> -9 dBm, -7 dBm (typ.)
	R&S® ZVA-Z220	
	140 GHz to 150 GHz	> -18 dBm (n. trc.), -12 dBm (typ.)
	150 GHz to 220 GHz	> -14 dBm (n. trc.), -10 dBm (typ.)
R&S® ZVA-Z325	> -22 dBm (n. trc.), -20 dBm (typ.)	
Output power attenuation	R&S® ZVA-Z75 manually adjustable	0 dB to 40 dB
	R&S® ZVA-Z90 adjustable by reduction of RF input power	0 dB to 70 dB
	R&S® ZVA-Z110	
	manually adjustable	0 dB to 40 dB
	adjustable by reduction of RF input power	0 dB to 70 dB
	R&S® ZVA-Z110E electronically adjustable	0 dB to 25 dB
	R&S® ZVA-Z220 manually adjustable	0 dB to 40 dB
R&S® ZVA-Z325 manually adjustable	0 dB to 40 dB	
Output power frequency response at minimum attenuation (peak-to-peak)	R&S® ZVA-Z75 at 0 dB attenuator setting	< 7 dB
	R&S® ZVA-Z90 at +7 dBm RF input power	< 7 dB
	R&S® ZVA-Z110 at 0 dB attenuator setting	< 7 dB
	R&S® ZVA-Z110E at 0 dB attenuator setting	< 7 dB
	R&S® ZVA-Z220 at 0 dB attenuator setting	< 12 dB (n. trc.)
	R&S® ZVA-Z325 at 0 dB attenuator setting	< 13 dB (n. trc.)
Damage level	R&S® ZVA-Z75/-Z90/-Z110/-Z110E/-Z140/-Z220	+20 dBm
	R&S® ZVA-Z325/-Z500	+10 dBm

**Source input (RF IN)**

Connector type	R&S® ZVA-Z75	3.5 mm, female
	R&S® ZVA-Z90	3.5 mm, female
	R&S® ZVA-Z110 and R&S® ZVA-Z110E	3.5 mm, female
	R&S® ZVA-Z220	3.5 mm, female
	R&S® ZVA-Z325	3.5 mm, female
Frequency range	R&S® ZVA-Z75	8.333 GHz to 12.5 GHz
	R&S® ZVA-Z90	10 GHz to 15 GHz
	R&S® ZVA-Z110 and R&S® ZVA-Z110E	12.5 GHz to 18.333 GHz
	R&S® ZVA-Z220	11.667 GHz to 18.333 GHz
	R&S® ZVA-Z325	12.222 GHz to 18.056 GHz
Input power range	R&S® ZVA-Z75	+5 dBm to +10 dBm
	R&S® ZVA-Z90	-15 dBm to +10 dBm
	R&S® ZVA-Z110	-15 dBm to +10 dBm
	R&S® ZVA-Z110E	+4 dBm to +10 dBm
	R&S® ZVA-Z220	+4 dBm to +10 dBm
R&S® ZVA-Z325	+4 dBm to +10 dBm	

**Local oscillator input (LO IN)**

Connector type	R&S® ZVA-Z75	3.5 mm, female
	R&S® ZVA-Z90	3.5 mm, female
	R&S® ZVA-Z110 and R&S® ZVA-Z110E	3.5 mm, female
	R&S® ZVA-Z220	3.5 mm, female
	R&S® ZVA-Z325	3.5 mm, female
Frequency range	R&S® ZVA-Z75	8.287 GHz to 12.454 GHz
	R&S® ZVA-Z90	9.954 GHz to 14.954 GHz
	R&S® ZVA-Z110 and R&S® ZVA-Z110E	9.34 GHz to 13.715 GHz
	R&S® ZVA-Z220	11.643 GHz to 18.31 GHz
	R&S® ZVA-Z325	13.733 GHz to 20.295 GHz
Input power range	R&S® ZVA-Z75	+5 dBm to +10 dBm
	R&S® ZVA-Z90	+5 dBm to +10 dBm
	R&S® ZVA-Z110 and R&S® ZVA-Z110E	+5 dBm to +10 dBm
	R&S® ZVA-Z220	+5 dBm to +10 dBm
R&S® ZVA-Z325	+5 dBm to +10 dBm	

**Measurement output (MEAS OUT)**

Connector type		SMA, female
Frequency range	R&S® ZVA-Z75	10 MHz to 300 MHz
	R&S® ZVA-Z90	10 MHz to 300 MHz
	R&S® ZVA-Z110 and R&S® ZVA-Z110E	10 MHz to 300 MHz
	R&S® ZVA-Z220	10 MHz to 300 MHz
	R&S® ZVA-Z325	10 MHz to 400 MHz

**Reference output (REF OUT)**

Connector type		SMA, female
Frequency range	R&S® ZVA-Z75	10 MHz to 300 MHz
	R&S® ZVA-Z90	10 MHz to 300 MHz
	R&S® ZVA-Z110 and R&S® ZVA-Z110E	10 MHz to 300 MHz
	R&S® ZVA-Z220	10 MHz to 300 MHz
	R&S® ZVA-Z325	10 MHz to 400 MHz

**Attenuation control input (ATT), R&S® ZVA-Z110E only**

Connector type	for connection to the EXTATT CTRL output of the R&S® ZVA vector network analyzer with R&S® ZVA-B8 option	series 711 connector, 3 pins
----------------	----------------------------------------------------------------------------------------------------------	------------------------------

## System characteristics

Trace stability	R&S® ZVA-Z75	< 0.2 dB (typ.) and < 2° (typ.)
	R&S® ZVA-Z90	< 0.2 dB (typ.) and < 2° (typ.)
	R&S® ZVA-Z110 and R&S® ZVA-Z110E	< 0.2 dB (typ.) and < 2° (typ.)
	R&S® ZVA-Z220	< 0.3 dB (typ.) and < 4° (typ.)
	R&S® ZVA-Z325	< 0.4 dB (typ.) and < 6° (typ.)
Trace stability is defined as the maximum deviation of the max. or min. hold trace of the reflection factor from its initial (reference) trace when measuring a converter whose waveguide port is terminated with a short. The data is valid if the ambient temperature of the R&S® ZVA/R&S® ZVT20 and the converter has not changed by more than 1 K over 1 hour, the output power of the converter is unattenuated and the measurement bandwidth is set to 100 Hz.		
Source match (without system error correction)	R&S® ZVA-Z75	> 19 dB, > 30 dB (typ.)
	R&S® ZVA-Z90	> 19 dB, > 30 dB (typ.)
	R&S® ZVA-Z110 and R&S® ZVA-Z110E	> 19 dB, > 30 dB (typ.)
	R&S® ZVA-Z220	> 25 dB (n. trc.) Fehler! Textmarke nicht definiert.
	R&S® ZVA-Z325	> 20 dB (n. trc.) Fehler! Textmarke nicht definiert.
Directivity (without system error correction)	R&S® ZVA-Z75	> 23 dB, > 37 dB (typ.)
	R&S® ZVA-Z90	> 23 dB, > 30 dB (typ.)
	R&S® ZVA-Z110 and R&S® ZVA-Z110E	> 23 dB, > 30 dB (typ.)
	R&S® ZVA-Z220	> 25 dB (n. trc.) Fehler! Textmarke nicht definiert.
	R&S® ZVA-Z325	> 20 dB (n. trc.) Fehler! Textmarke nicht definiert.
Effective source match (with system error correction)	R&S® ZVA-Z75	> 35 dB (meas.)
	R&S® ZVA-Z90	> 35 dB (meas.)
	R&S® ZVA-Z110 and R&S® ZVA-Z110E	> 35 dB (meas.)
	R&S® ZVA-Z220	> 30 dB (meas.)
	R&S® ZVA-Z325	> 30 dB (meas.)
Effective directivity (with system error correction)	R&S® ZVA-Z75	> 35 dB (meas.)
	R&S® ZVA-Z90	> 35 dB (meas.)
	R&S® ZVA-Z110 and R&S® ZVA-Z110E	> 35 dB (meas.)
	R&S® ZVA-Z220	> 30 dB (meas.)
	R&S® ZVA-Z325	> 30 dB (meas.)
Dynamic range	R&S® ZVA-Z75	> 90 dB, 110 dB (typ.)
	R&S® ZVA-Z90	> 100 dB, 115 dB (typ.)
	R&S® ZVA-Z110	> 100 dB, 110 dB (typ.)
	R&S® ZVA-Z110E	> 90 dB, 105 dB (typ.)
	R&S® ZVA-Z220	> 85 dB, 105 dB (typ.)
	R&S® ZVA-Z325	> 80 dB, 100 dB (typ.)
Dynamic range is defined as the difference between the data trace of the transmission magnitude with maximum test port output power and both test ports through-connected on the one hand and the RMS value of the data trace of the transmission magnitude produced by noise and crosstalk with test ports short-circuited on the other. The specification is valid without system error correction and at 10 Hz measurement bandwidth. The dynamic range can be increased by using a measurement bandwidth of 1 Hz.		



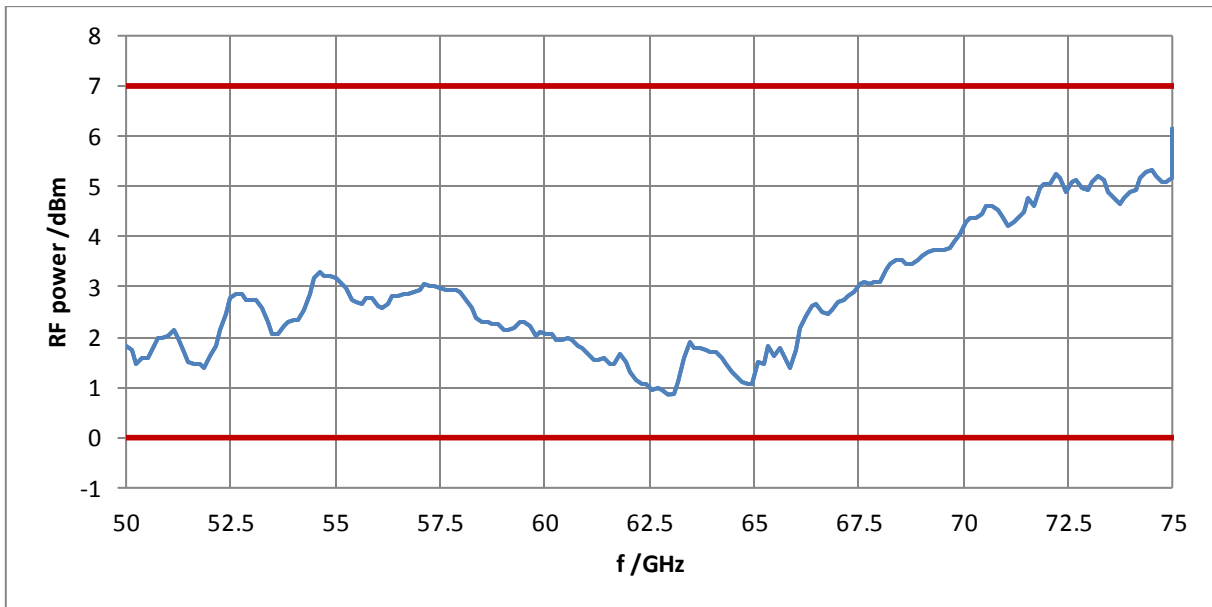

Test port output power versus frequency of the R&S®ZVA-Z75.

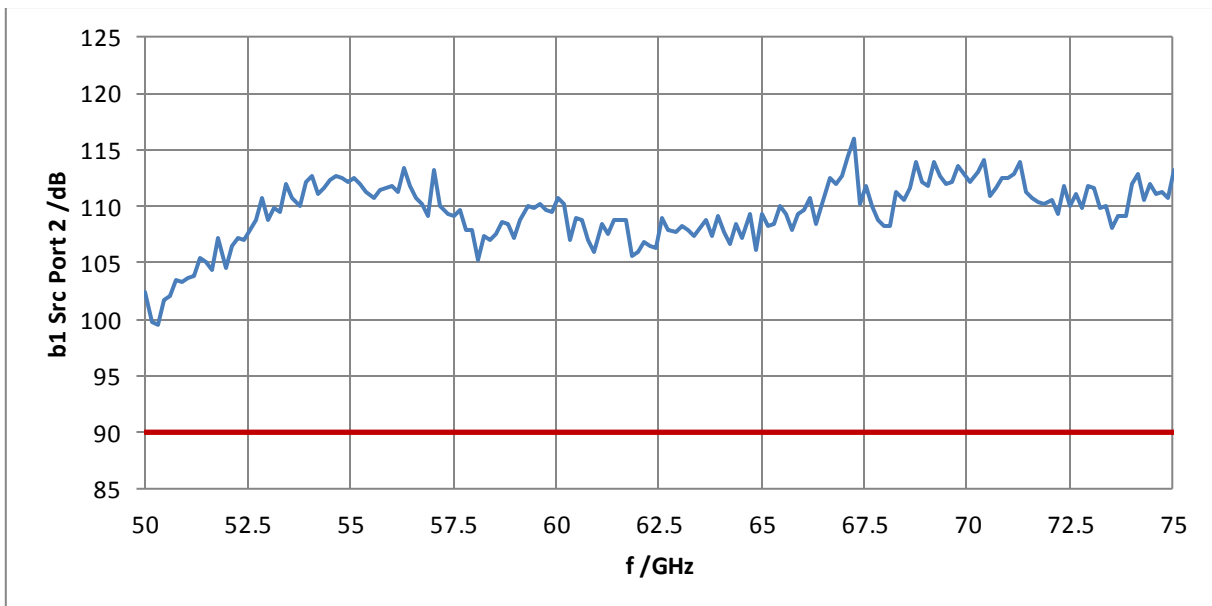

Dynamic range in dB versus frequency of the R&S®ZVA-Z75.

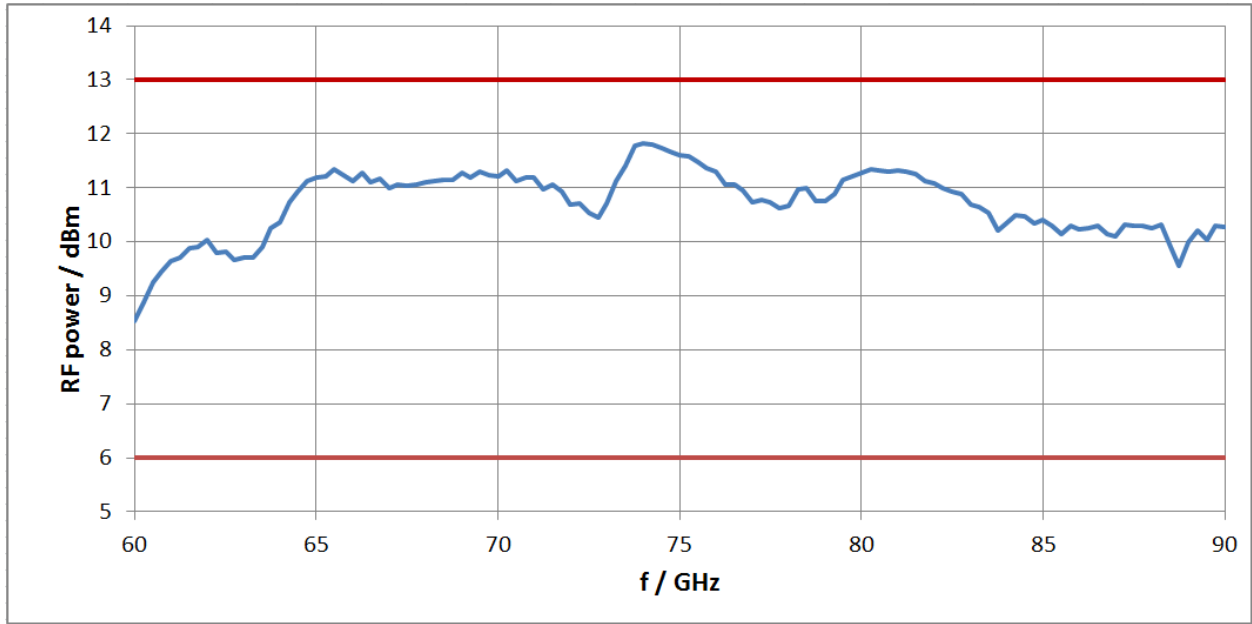

Test port output power versus frequency of the R&S®ZVA-Z90.

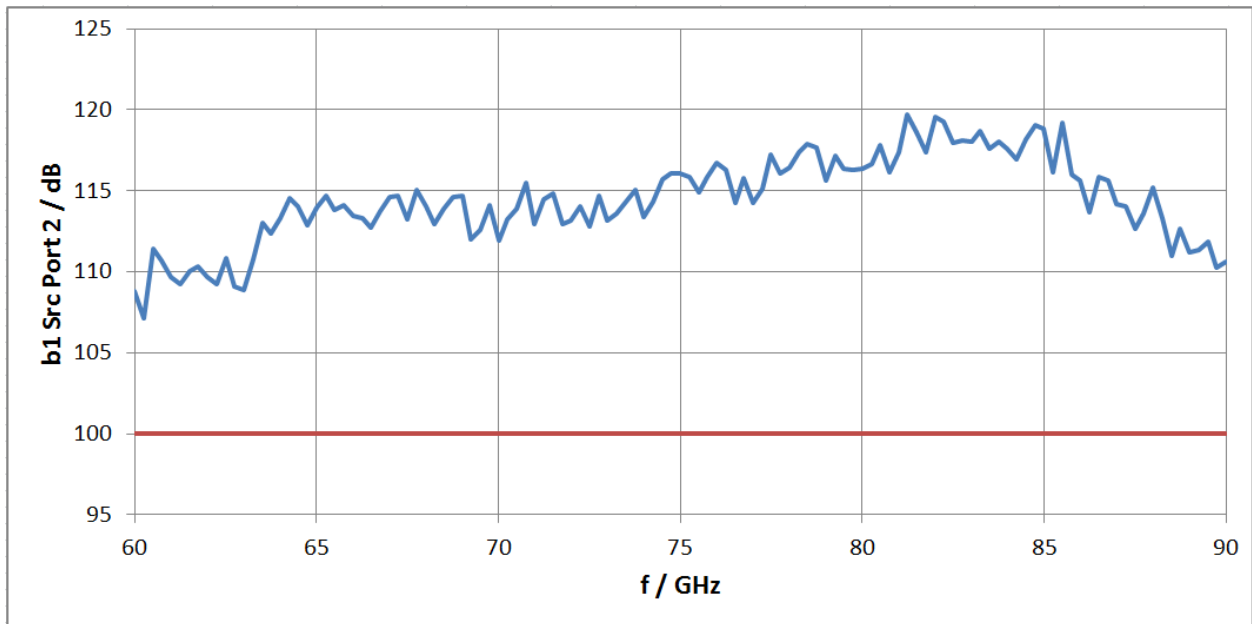

Dynamic range in dB versus frequency of the R&S®ZVA-Z90.

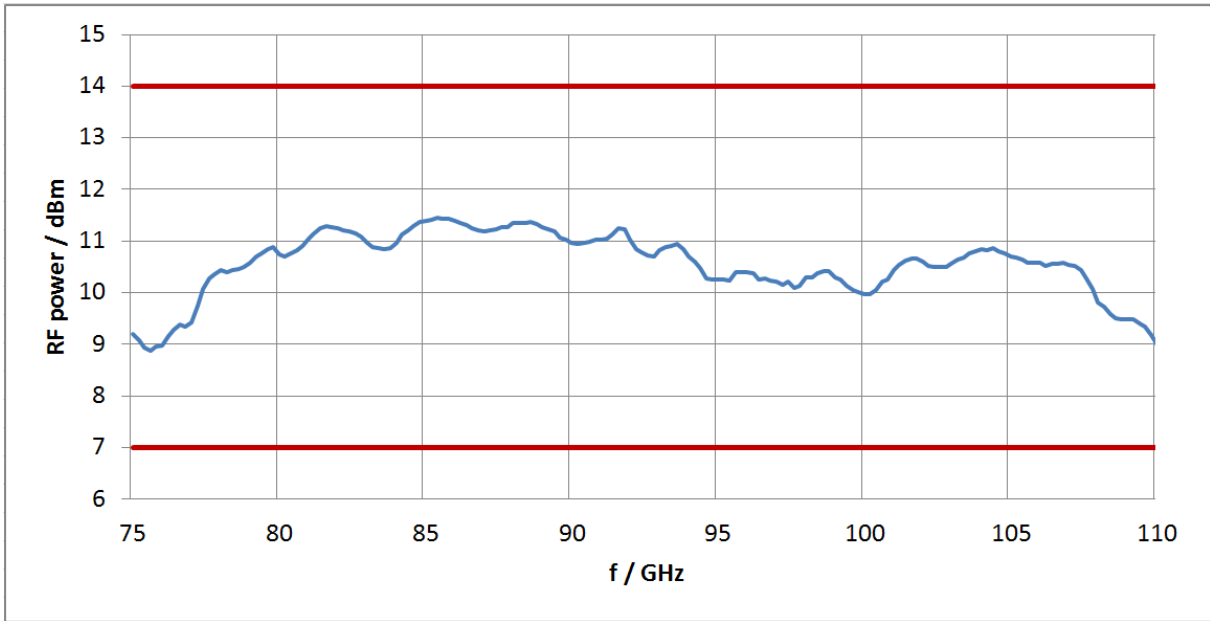

Test port output power versus frequency of the R&S®ZVA-Z110.

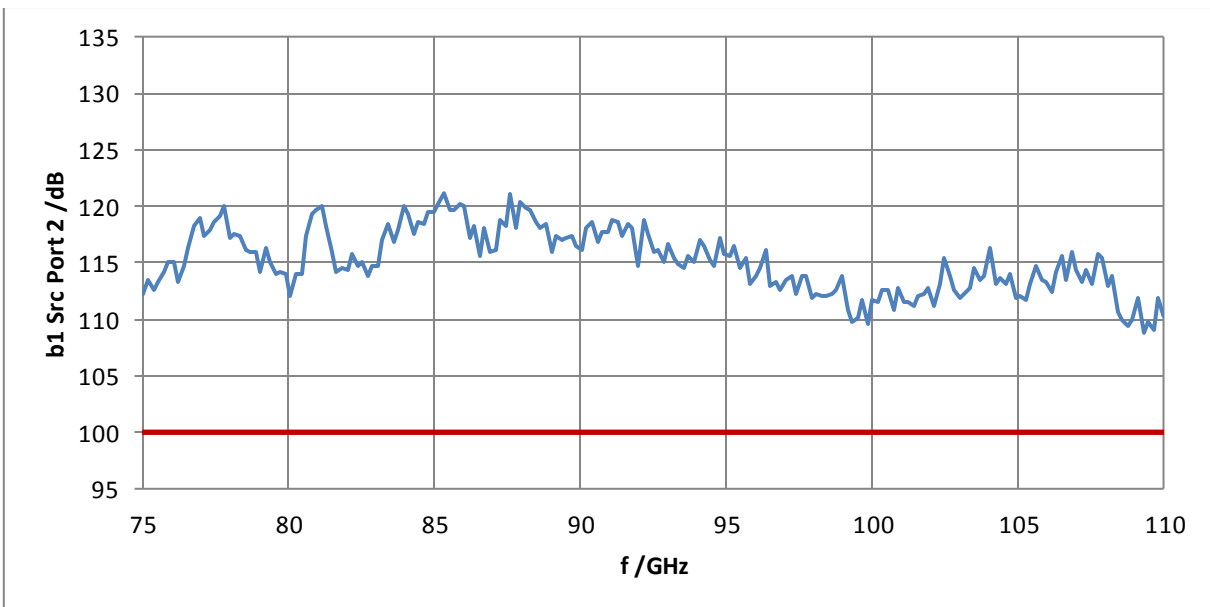

Dynamic range in dB versus frequency of the R&S®ZVA-Z110.

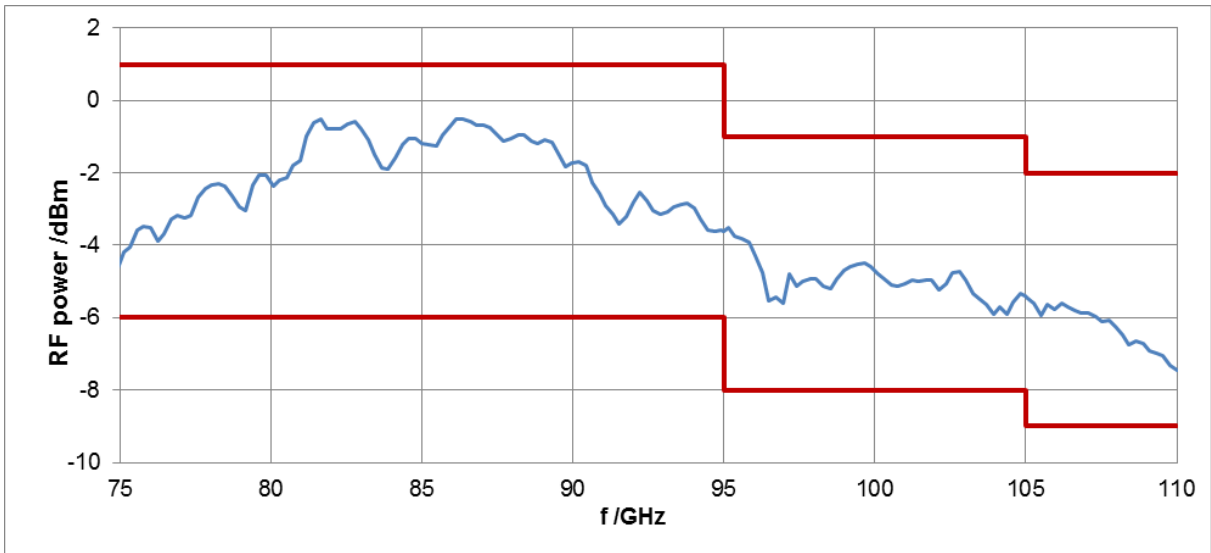

Test port output power versus frequency of the R&S®ZVA-Z110E.

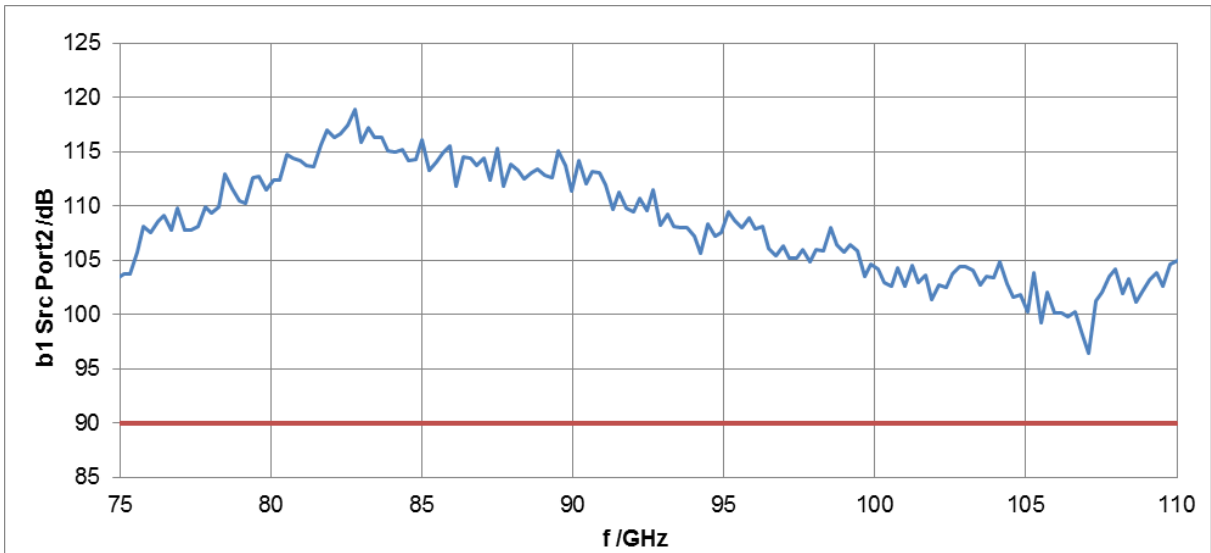

Dynamic range in dB versus frequency of the R&S®ZVA-Z110E.

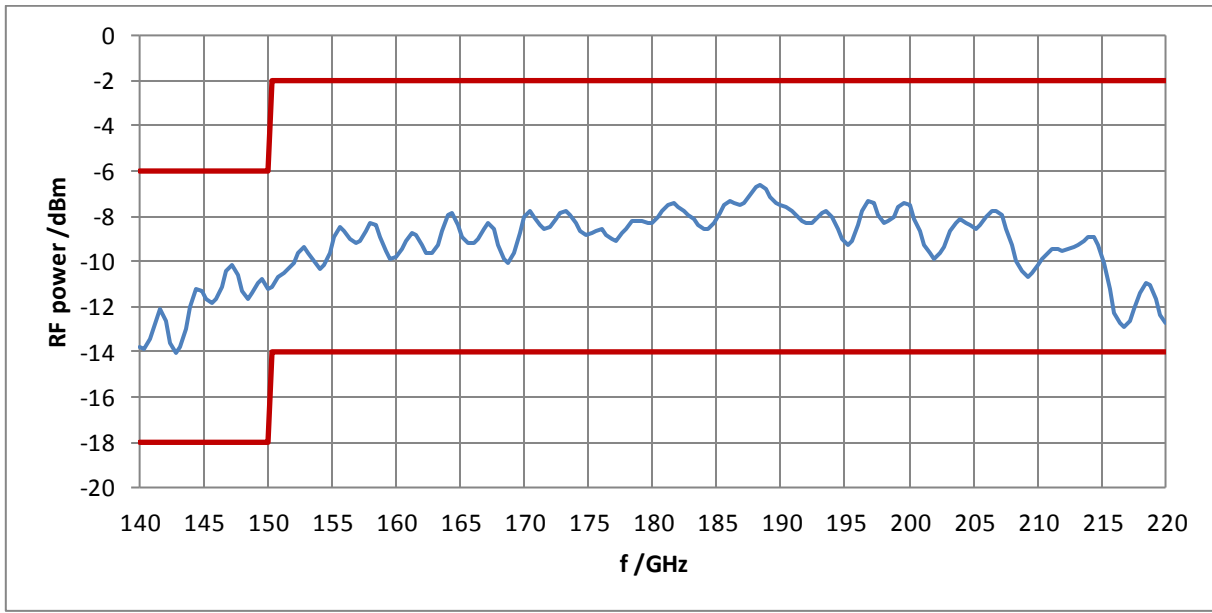

Test port output power versus frequency of the R&S®ZVA-Z220.

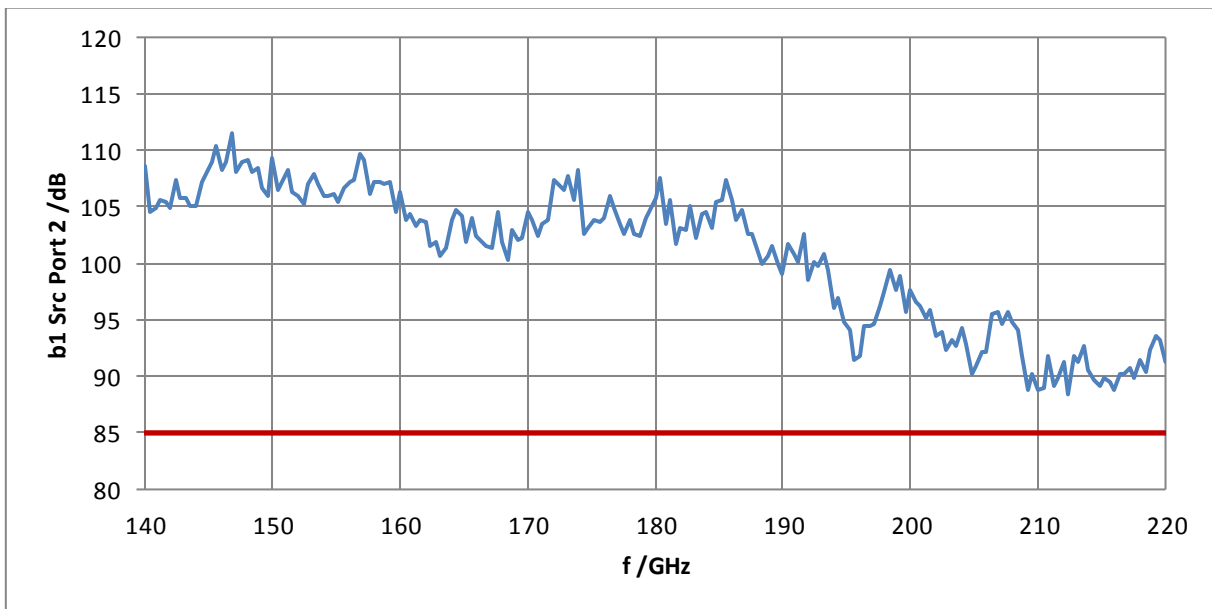

Dynamic range in dB versus frequency of the R&S®ZVA-Z220.

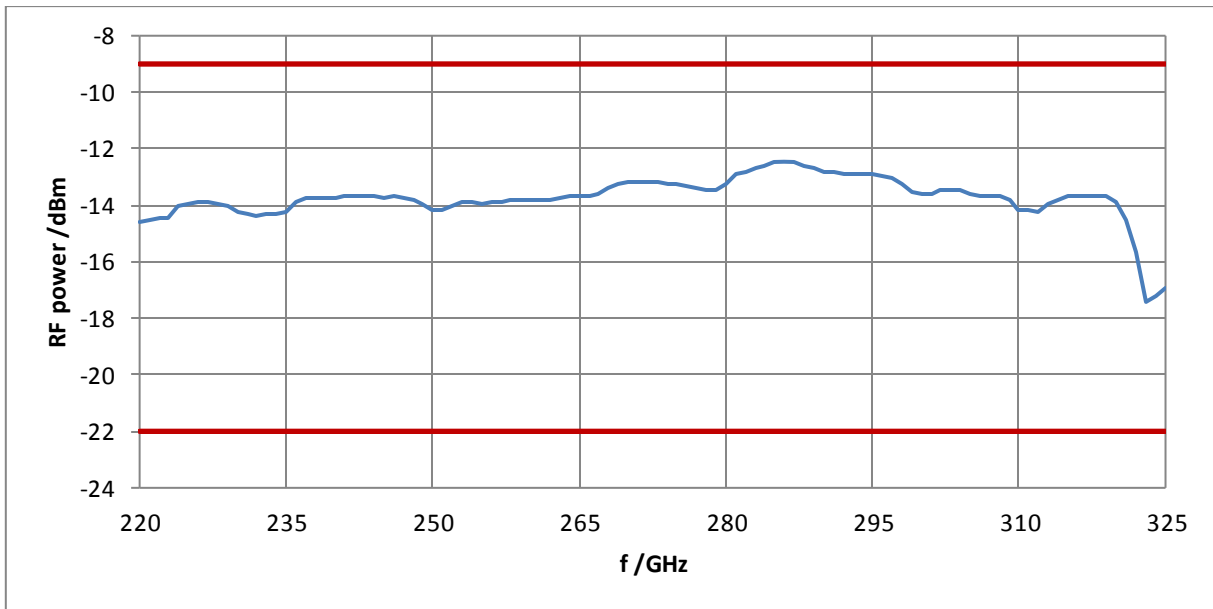

Test port output power versus frequency of the R&S®ZVA-Z325.

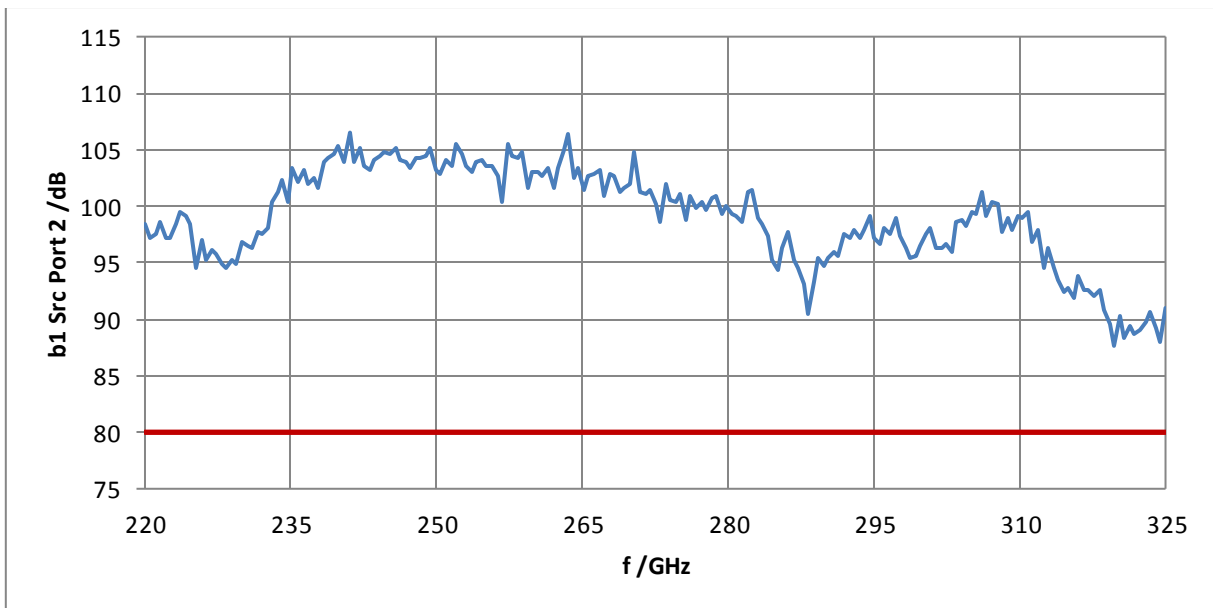

Dynamic range in dB versus frequency of the R&S®ZVA-Z325.

## Power supply input

Connector type		DIN 45323 power connector
Voltage		+9 V ± 540 mV
Current	R&S® ZVA-Z75/R&S® ZVA-Z90/ R&S® ZVA-Z110/R&S® ZVA-Z110E/ R&S® ZVA-Z140/R&S® ZVA-Z220/ R&S® ZVA-Z325	< 1.1 A
	R&S® ZVA-Z500	< 1.6 A

## General data

Temperature loading	operating temperature range	+18 °C to +28 °C
	permissible temperature range	+5 °C to +40 °C
	storage temperature range	-40 °C to +70 °C
Damp heat		in line with IEC 60068-2-1 and IEC 60068-2-2
		+40 °C at 80 % rel. humidity, in line with IEC 60068-2-30
Mechanical resistance	vibration, sinusoidal	5 Hz to 150 Hz, in line with IEC 60068-2-6
	vibration, random	10 Hz to 300 Hz, in line with IEC 60068-2-64
	shock	40 g shock spectrum, in line with IEC 60068-2-27, MIL-STD-810
Dimensions (W x H x D)	with feet height adjusted to 12.1 mm (0.5 in)	
	R&S® ZVA-Z75	413 mm x 110 mm x 114 mm (16.3 in x 4.3 in x 4.5 in)
	R&S® ZVA-Z90	286 mm x 78 mm x 114 mm (11.3 in x 3.1 in x 4.5 in)
	R&S® ZVA-Z110 and R&S® ZVA-Z110E	361 mm x 110 mm x 114 mm (14.2 in x 4.3 in x 4.5 in)
	R&S® ZVA-Z140	355 mm x 110 mm x 114 mm (14.0 in x 4.3 in x 4.5 in)
	R&S® ZVA-Z220	328 mm x 110 mm x 114 mm (12.9 in x 4.3 in x 4.5 in)
	R&S® ZVA-Z325	251 mm x 110 mm x 114 mm (9.9 in x 4.3 in x 4.5 in)
	R&S® ZVA-Z500	257 mm x 110 mm x 114 mm (10.1 in x 4.3 in x 4.5 in)
Number of feet	alternatively	3 or 4
Feet height	user-adjustable	12.1 mm to 29.1 mm (0.5 in to 1.1 in)
Weight		3 kg (7 lb)
Shipping weight		5 kg (11 lb)

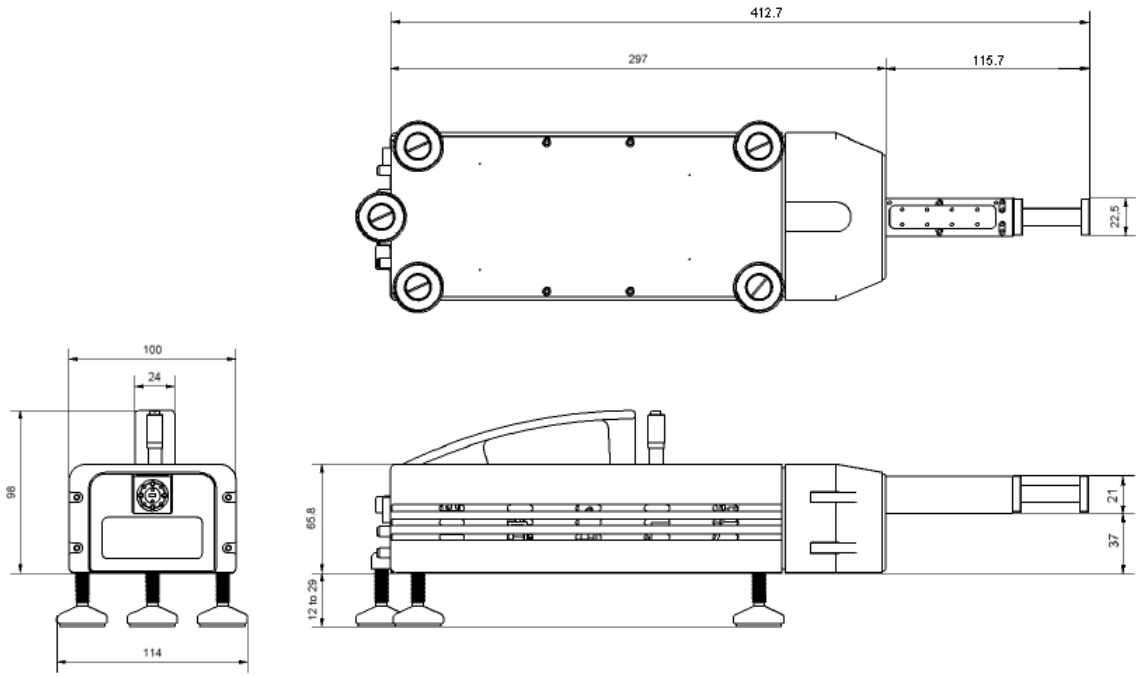

Dimensions (in mm) of the R&S®ZVA-Z75.

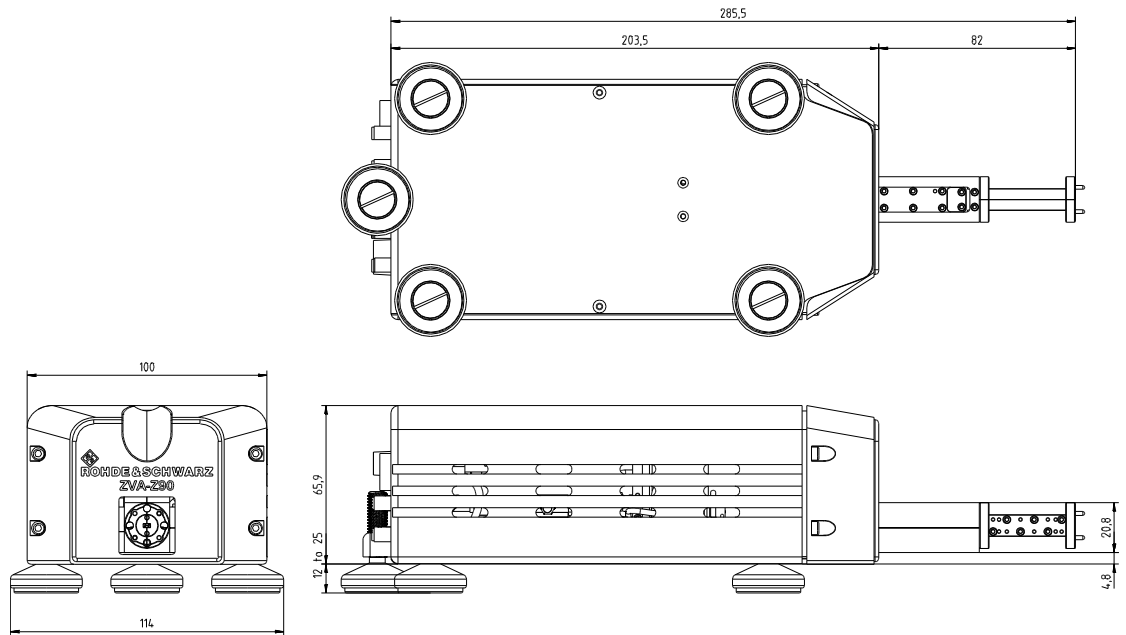

Dimensions (in mm) of the R&S®ZVA-Z90.



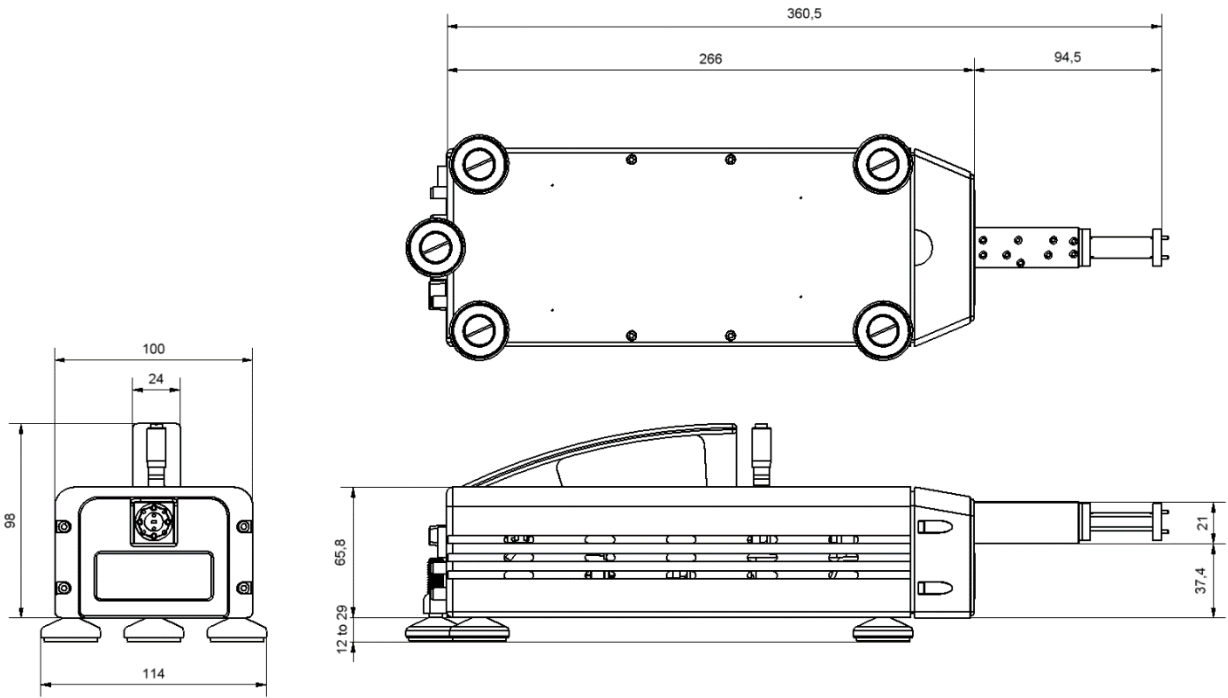

Dimensions (in mm) of the R&S® ZVA-Z110.

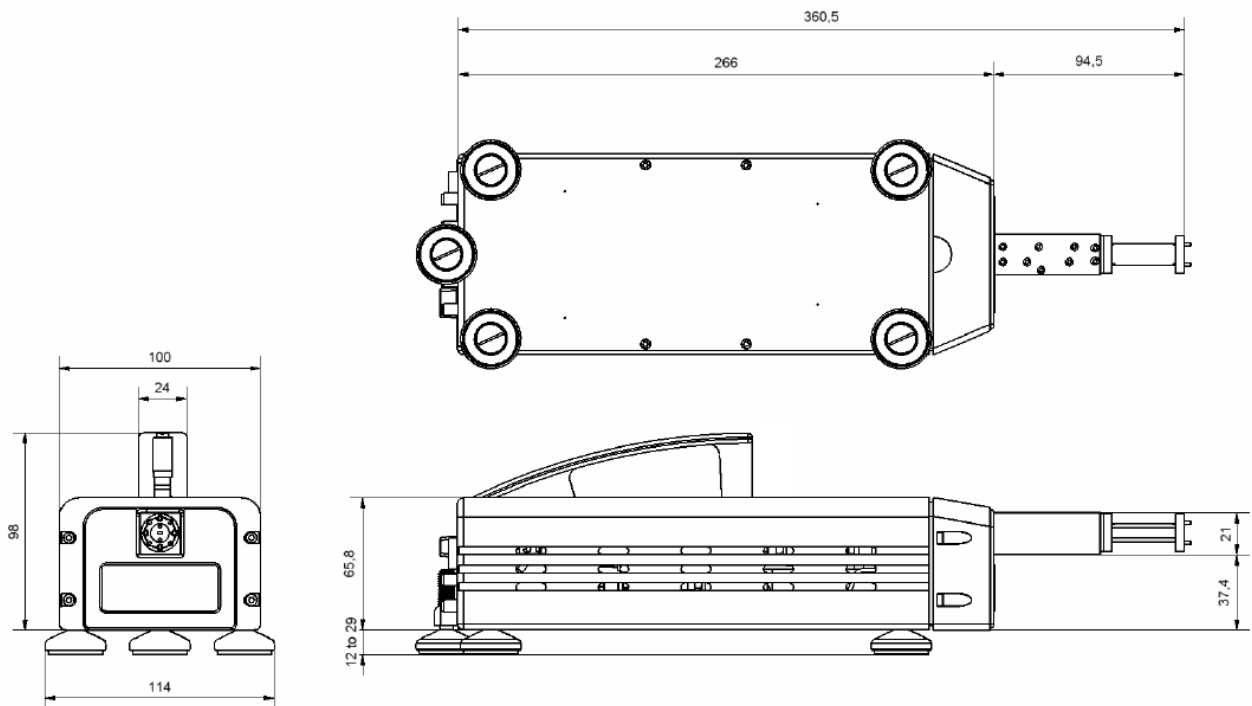

Dimensions (in mm) of the R&S® ZVA-Z110E.

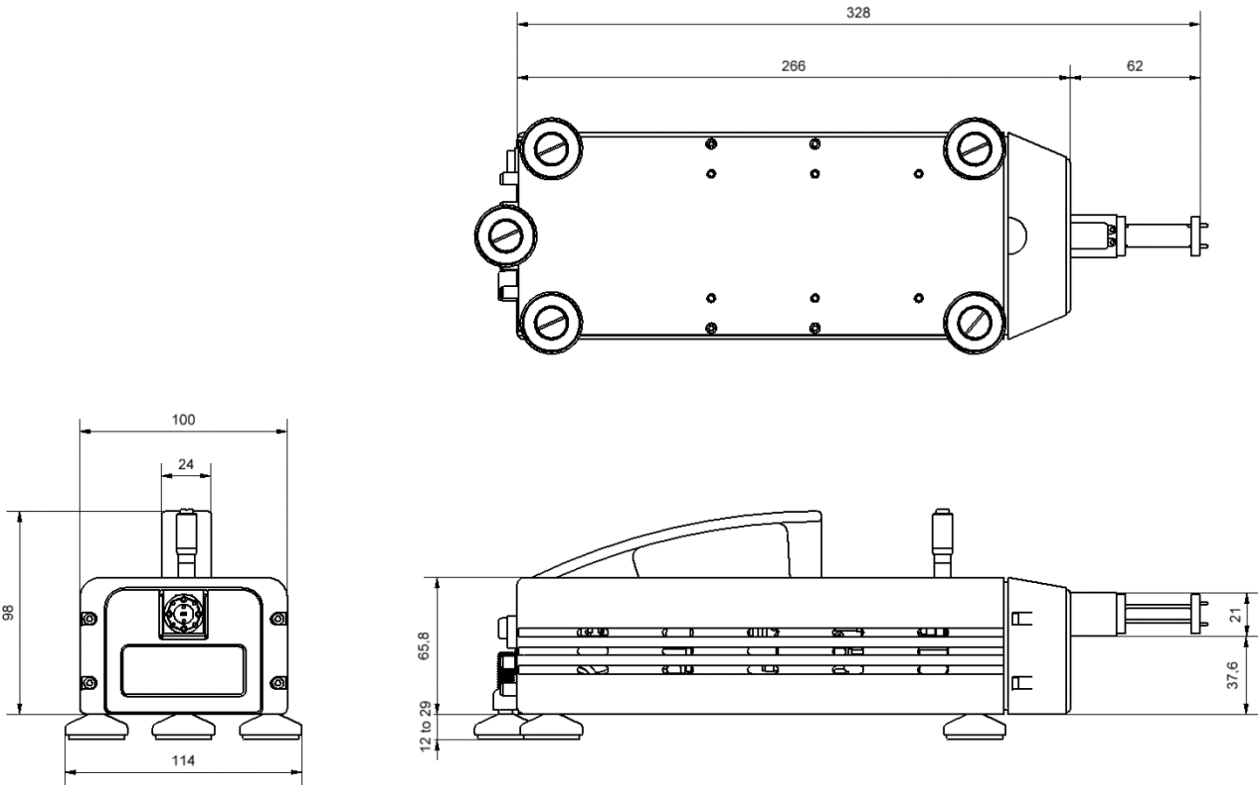

Dimensions (in mm) of the R&S®ZVA-Z220.

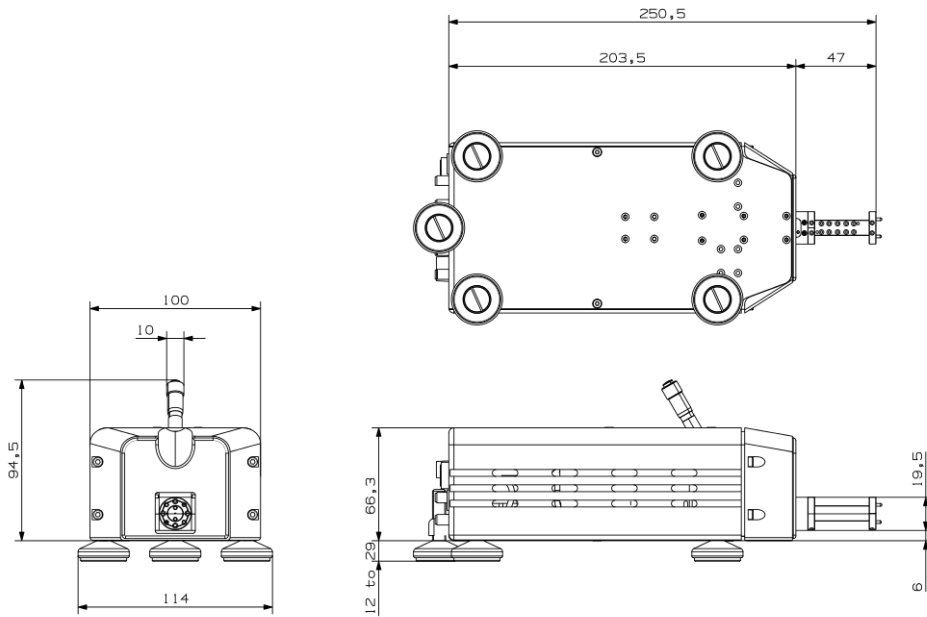

Dimensions (in mm) of the R&S®ZVA-Z325.

## Ordering information

Designation	Type	Order No.
Converter WR15	R&S <sup>®</sup> ZVA-Z75	1307.7400.02
Converter WR12	R&S <sup>®</sup> ZVA-Z90	1322.3024.02
Converter WR10	R&S <sup>®</sup> ZVA-Z110	1307.7000.03
Converter WR10	R&S <sup>®</sup> ZVA-Z110E	1307.7000.40
Converter WR05	R&S <sup>®</sup> ZVA-Z220	1307.8006.02
Converter WR03	R&S <sup>®</sup> ZVA-Z325	1317.0514.02
Test Port Cable 3.5 mm female to 3.5 mm male, 965 mm (two cables per converter required)	R&S <sup>®</sup> ZV-Z193	1306.4520.36
Waveguide Calibration Kit WR15 (without sliding matches)	R&S <sup>®</sup> ZV-WR15	1307.7500.30
Waveguide Calibration Kit WR15 (with sliding match)	R&S <sup>®</sup> ZV-WR15	1307.7500.31
Waveguide Calibration Kit WR12 (without sliding matches)	R&S <sup>®</sup> ZV-WR12	1307.7700.10
Waveguide Calibration Kit WR12 (with sliding match)	R&S <sup>®</sup> ZV-WR12	1307.7700.11
Waveguide Calibration Kit WR10 (without sliding matches)	R&S <sup>®</sup> ZV-WR10	1307.7100.10
Waveguide Calibration Kit WR10 (with sliding match)	R&S <sup>®</sup> ZV-WR10	1307.7100.11
Waveguide Calibration Kit WR08 (without sliding matches)	R&S <sup>®</sup> ZV-WR08	1307.7900.10
Waveguide Calibration Kit WR08 (with sliding match)	R&S <sup>®</sup> ZV-WR08	1307.7900.11
Waveguide Calibration Kit WR06 (without sliding matches)	R&S <sup>®</sup> ZV-WR06	1311.8807.10
Waveguide Calibration Kit WR06 (with sliding match)	R&S <sup>®</sup> ZV-WR06	1311.8807.11
Waveguide Calibration Kit WR05 (without sliding matches)	R&S <sup>®</sup> ZV-WR05	1307.8106.10
Waveguide Calibration Kit WR05 (with sliding match)	R&S <sup>®</sup> ZV-WR05	1307.8106.11
Waveguide Calibration Kit WR03 (without sliding matches)	R&S <sup>®</sup> ZV-WR03	1307.7300.30
Waveguide Calibration Kit WR03 (with sliding match)	R&S <sup>®</sup> ZV-WR03	1307.7300.31
Waveguide Calibration Kit WR02 (without sliding match)	R&S <sup>®</sup> ZV-WR02	1314.5550.10
External Attenuator Control for R&S <sup>®</sup> ZVA-Z110E	R&S <sup>®</sup> ZVA-B8	1307.6026.02
Converter Control Software	R&S <sup>®</sup> ZVA-K8	1307.7022.02

Service options		
Extended Warranty, one year	R&S <sup>®</sup> WE1	Please contact your local Rohde & Schwarz sales office.
Extended Warranty, two years	R&S <sup>®</sup> WE2	
Extended Warranty, three years	R&S <sup>®</sup> WE3	
Extended Warranty, four years	R&S <sup>®</sup> WE4	
Extended Warranty with Calibration Coverage, one year	R&S <sup>®</sup> CW1	
Extended Warranty with Calibration Coverage, two years	R&S <sup>®</sup> CW2	
Extended Warranty with Calibration Coverage, three years	R&S <sup>®</sup> CW3	
Extended Warranty with Calibration Coverage, four years	R&S <sup>®</sup> CW4	

### Extended warranty with a term of one to four years (WE1 to WE4)

Repairs carried out during the contract term are free of charge<sup>1</sup>. Necessary calibration and adjustments carried out during repairs are also covered. Simply contact the forwarding agent we name; your product will be picked up free of charge and returned to you in top condition a couple of days later.

### Extended warranty with calibration (CW1 to CW4)

Enhance your extended warranty by adding calibration coverage at a package price. This package ensures that your Rohde & Schwarz product is regularly calibrated, inspected and maintained during the term of the contract. It includes all repairs<sup>1</sup> and calibration at the recommended intervals as well as any calibration carried out during repairs or option upgrades.

<sup>1</sup> Excluding defects caused by incorrect operation or handling and force majeure. Wear-and-tear parts are not included.

## Service that adds value

- | Worldwide
- | Local and personalized
- | Customized and flexible
- | Uncompromising quality
- | Long-term dependability

## Rohde & Schwarz

The Rohde & Schwarz electronics group offers innovative solutions in the following business fields: test and measurement, broadcast and media, secure communications, cybersecurity, monitoring and network testing. Founded more than 80 years ago, the independent company which is headquartered in Munich, Germany, has an extensive sales and service network with locations in more than 70 countries.

## Sustainable product design

- | Environmental compatibility and eco-footprint
- | Energy efficiency and low emissions
- | Longevity and optimized total cost of ownership

Certified Quality Management

**ISO 9001**

Certified Environmental Management

**ISO 14001**

## Rohde & Schwarz GmbH & Co. KG

[www.rohde-schwarz.com](http://www.rohde-schwarz.com)

## Rohde & Schwarz training

[www.training.rohde-schwarz.com](http://www.training.rohde-schwarz.com)

## Regional contact

- | Europe, Africa, Middle East | +49 89 4129 12345  
[customersupport@rohde-schwarz.com](mailto:customersupport@rohde-schwarz.com)
- | North America | 1 888 TEST RSA (1 888 837 87 72)  
[customer.support@rsa.rohde-schwarz.com](mailto:customer.support@rsa.rohde-schwarz.com)
- | Latin America | +1 410 910 79 88  
[customersupport.la@rohde-schwarz.com](mailto:customersupport.la@rohde-schwarz.com)
- | Asia Pacific | +65 65 13 04 88  
[customersupport.asia@rohde-schwarz.com](mailto:customersupport.asia@rohde-schwarz.com)
- | China | +86 800 810 82 28 | +86 400 650 58 96  
[customersupport.china@rohde-schwarz.com](mailto:customersupport.china@rohde-schwarz.com)

R&S® is a registered trademark of Rohde & Schwarz GmbH & Co. KG

Trade names are trademarks of the owners

PD 5214.2033.22 | Version 18.00 | June 2017 (we)

R&S®ZVA-Zxx Millimeter-Wave Converters

Data without tolerance limits is not binding | Subject to change

© 2008 - 2017 Rohde & Schwarz GmbH & Co. KG | 81671 Munich, Germany



5214203322